

Reticle Information

for NXS and Precision Benchrest Riflescopes

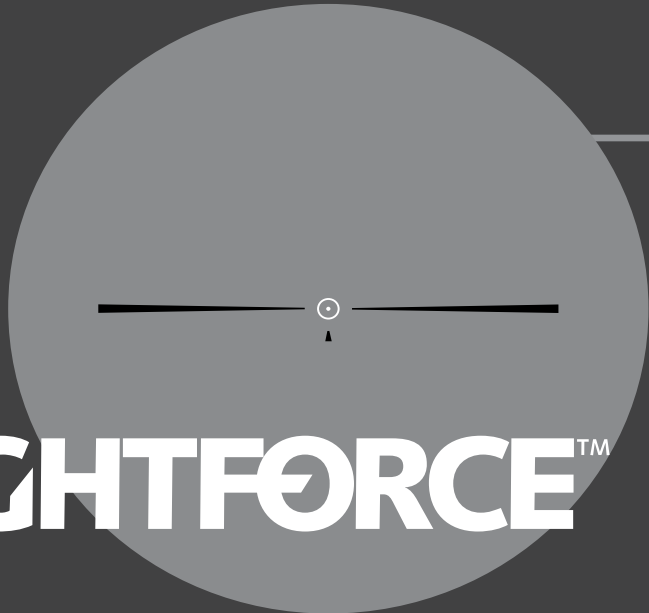
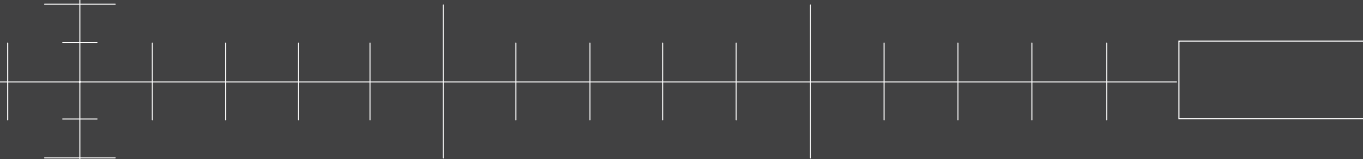

NIGHTFORCE™

Contents

Ranging Power Ring Settings.....	1
NP-1 RR.....	2
NP-1.....	4
NP-R1.....	5
NP-R2.....	7
NP-2DD.....	9
CH-1.....	11
CH-2.....	12
CH-3.....	13
MLR.....	14
MIL-DOT.....	16
FC-2.....	18
Ranging.....	19

Nightforce Reticles

All Nightforce reticles are etched on precision multi-coated compound glass. This ensures exact alignment and eliminates breakage. They are equipped with reticle illumination that aids in creating the ideal contrast with the target regardless of the ambient light level. This type of reticle is substantially stronger than outdated wire reticles that may break or distort under extreme recoil or impact plus it allows the design of truly innovative reticles that would be impossible to create otherwise.

If desired, the reticle can be changed for a nominal fee.

Ranging Power Ring Settings

If your rifle scope has a ranging reticle, the power setting for using the ranging features at their listed spacing, may be marked with an "R" on the power zoom ring. If no "R" marking is found then set it to the corresponding power zoom setting as shown in the chart below.

All models are calibrated to give the specified distance spacing at the following power zoom settings:

1-4x @ 4x	2.5-10x @ 10x
3.5-15x @ 15x	5.5-22x @ 22x
8-32x @ 22x (R)	12-42x @ 22x (R)

NP-1RR

Major Functions

- Easy ranging of the target in the field with no mathematical calculations.
- Quick and accurate compensation for wind drift and bullet drop.

The NP1-RR ranging scale works on the principle of known size of the target in inches. The diagram above is a breakdown of the ranging scale: step, circle, baseline and yards. Distance from step to baseline (inside edges) = 18 inches. Diameter of circle = 9 inches. Distance from bottom of circle to baseline = 9 inches.

Examples

- Deer average 18–20 inches from brisket to shoulder.
- Coyotes average 18–20 inches in height.
- Fox average 10–12 inches in height.
- Prairie dogs average 9–10 inches standing.

The ranging scale remains effective in the field even with small variances in target size.

You can recalibrate the ranging scale in your Nightforce scope for target sizes other than 18 inches and 9 inches.

Decreasing magnification from specified settings will increase values of the ranging scale and bullet drop scale. Increasing magnification will have the opposite effect and will decrease values.

Example

Recalibrating the ranging scale for a 20-inch target

Place a target 20 inches in height, exactly 300 yards away. Looking through the scope at the target, decrease the magnification until the inside edges of the step and the baseline bracket the target in the 300 yard column. Mark your magnification ring at this point to align with the indicator mark on the tube body. Your scope is now capable of ranging 9 inch, 18 inch and 20 inch targets, depending on the magnification you have the scope set on. This can be done for a wide range of target sizes if desired.

Suggested Use

Varmint, long-range hunting

NP-1RR

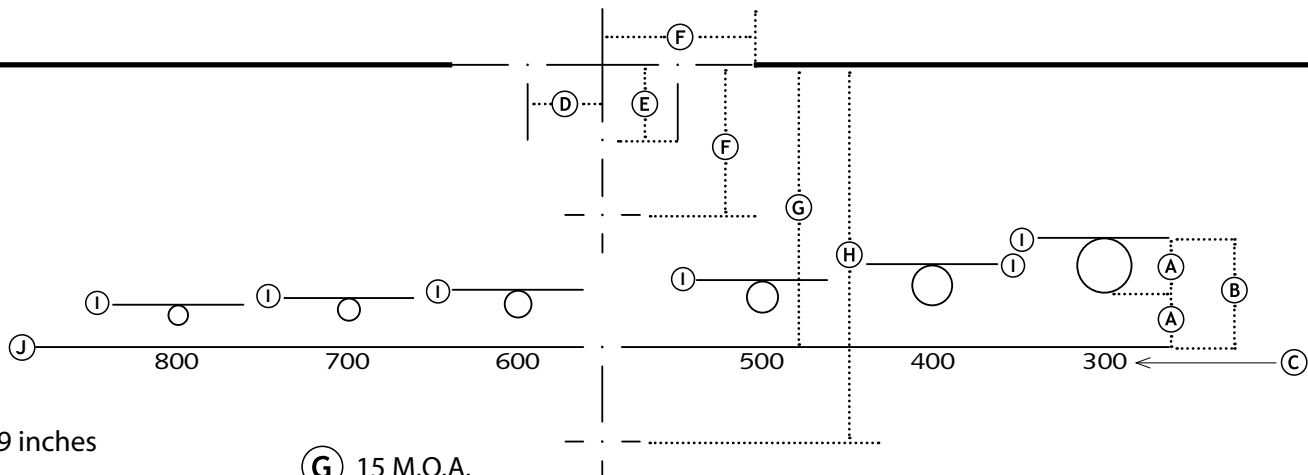

- (A)** 9 inches
- (B)** 18 inches
- (C)** Distance in Yards
- (D)** 4 M.O.A.
- (E)** 4 M.O.A.
- (F)** 8 M.O.A.
- (G)** 15 M.O.A.
- (H)** 20 M.O.A.
- (I)** Step
- (J)** Baseline

<i>Riflescope Model</i>	<i>Ranging Power</i>
3.5-15x NXS	15x
5.5-22x NXS	22x
8-32x NXS and Benchrest	22x*
12-42x NXS and Benchrest	22x*
*Signified by an "R" on the Power Zoom Ring	

NP-1

Superior to duplex reticles, this floating three-plex design utilizes all the functional elements of a duplex without unnecessary obstructions of your field of view at the 12 o'clock and 6 o'clock positions. Measured at 22x, a fine crosshair with a .080 M.O.A. subtension extends 4 M.O.A. from center and is bracketed by heavy bars at the 3 o'clock, 6 o'clock and 9 o'clock positions. The NP-1 directs your eye to center for quick target acquisition.

Nightforce owners and members of our own staff pick the NP-1 as their preferred reticle for traditional hunting.

- Ⓐ 12 M.O.A. @ 4x, 5 M.O.A. @ 10x, 6.3 M.O.A. @ 15x, 4 M.O.A. @ 22x, 2.8 M.O.A. @ 32x, 2.1 M.O.A. @ 42x
- Ⓑ 12 M.O.A. @ 4x, 5 M.O.A. @ 10x, 6.3 M.O.A. @ 15x, 4 M.O.A. @ 22x, 2.8 M.O.A. @ 32x, 2.1 M.O.A. @ 42x
- Ⓒ Line Thickness = .30 M.O.A. @ 4x, .13 M.O.A. @ 10x, 0.125 M.O.A. @ 15x, .080 M.O.A. @ 22x, .06 M.O.A. @ 32x, .04 M.O.A. @ 42x
- Ⓓ 12 M.O.A. @ 4x, 5 M.O.A. @ 10x, 7.9 M.O.A. @ 15x, 5 M.O.A. @ 22x, 3.6 M.O.A. @ 32x, 2.7 M.O.A. @ 42x
- Ⓔ Line Thickness = 2.0 M.O.A. @ 4x, .75 M.O.A. @ 10x, .39 M.O.A. @ 15x, .25 M.O.A. @ 22x, .18 M.O.A. @ 32x, .13 M.O.A. @ 42x

Riflescope Model	Ranging Power
1-4x NXS	4x
3.5-15x NXS	15x
5.5-22x NXS	22x
8-32x NXS and Benchrest	22x*
12-42x NXS and Benchrest	22x*

*Signified by an "R" on the Power Zoom Ring

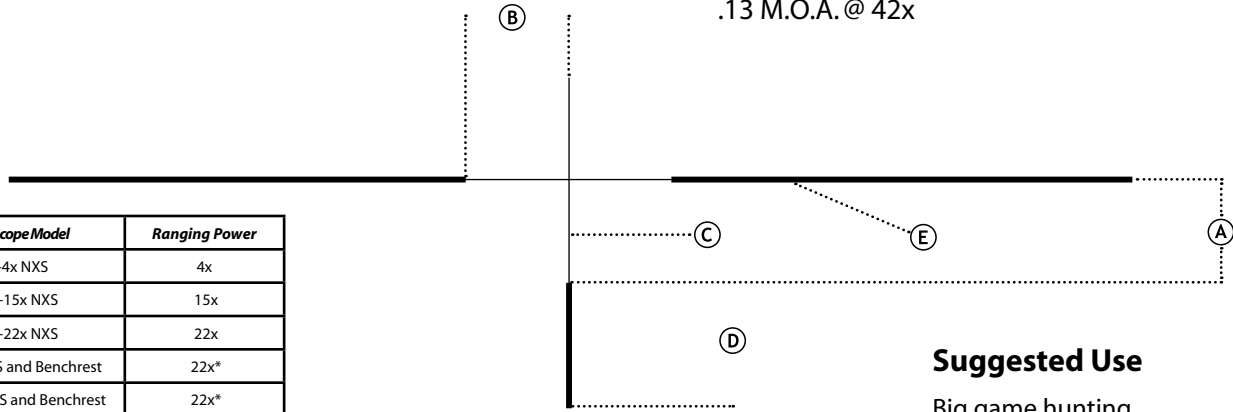

Suggested Use
Big game hunting

NP-R1

The NP-R1 reticle provides the smallest graduations on the vertical line of any Nightforce reticle. The 1 M.O.A. elevation spacing and 2 M.O.A. windage spacing is ideal for precision long range shooting but also works well for benchrest or all-around use.

The uncluttered field of view in the four quadrants provides a clear image of the target and surroundings, without sacrificing the ability to use multiple holdover or windage points when needed.

The 1 M.O.A. spaced vertical “ladder” or the 2 M.O.A. spaced windage tics can be used for ranging objects of varied sizes rather than being locked into one or two dimensions. Whatever the known target height, you can usually determine the range by superimposing the reticle over the target and bracketing it between two points on the reticle. Any size target can be easily ranged using a simple formula: (target size in inches ÷ M.O.A. x 100 = range in yards).

Note: The 3.5-15x models have additional lines on the vertical and horizontal axes with the NP-R1 reticle. See Figure 1.

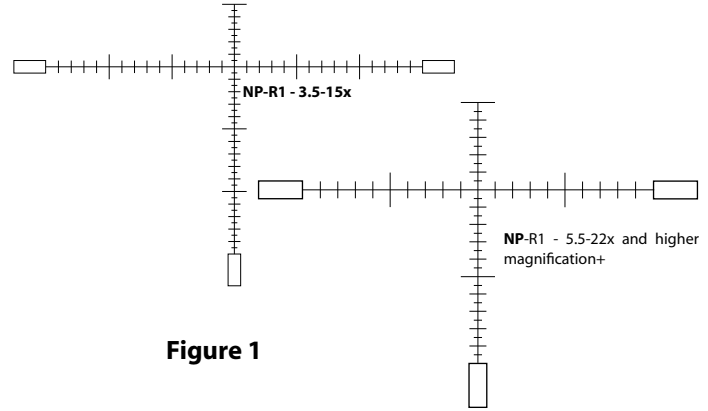

Figure 1

Suggested Use

Field tactical, varmint, long-range hunting

Riflescope Model	Ranging Power
3.5-15x NXS	15x
5.5-22x NXS	22x
8-32x NXS	22x*
12-42x NXS	22x*
*Signified by an "R" on the Power Zoom Ring	

NP-R1

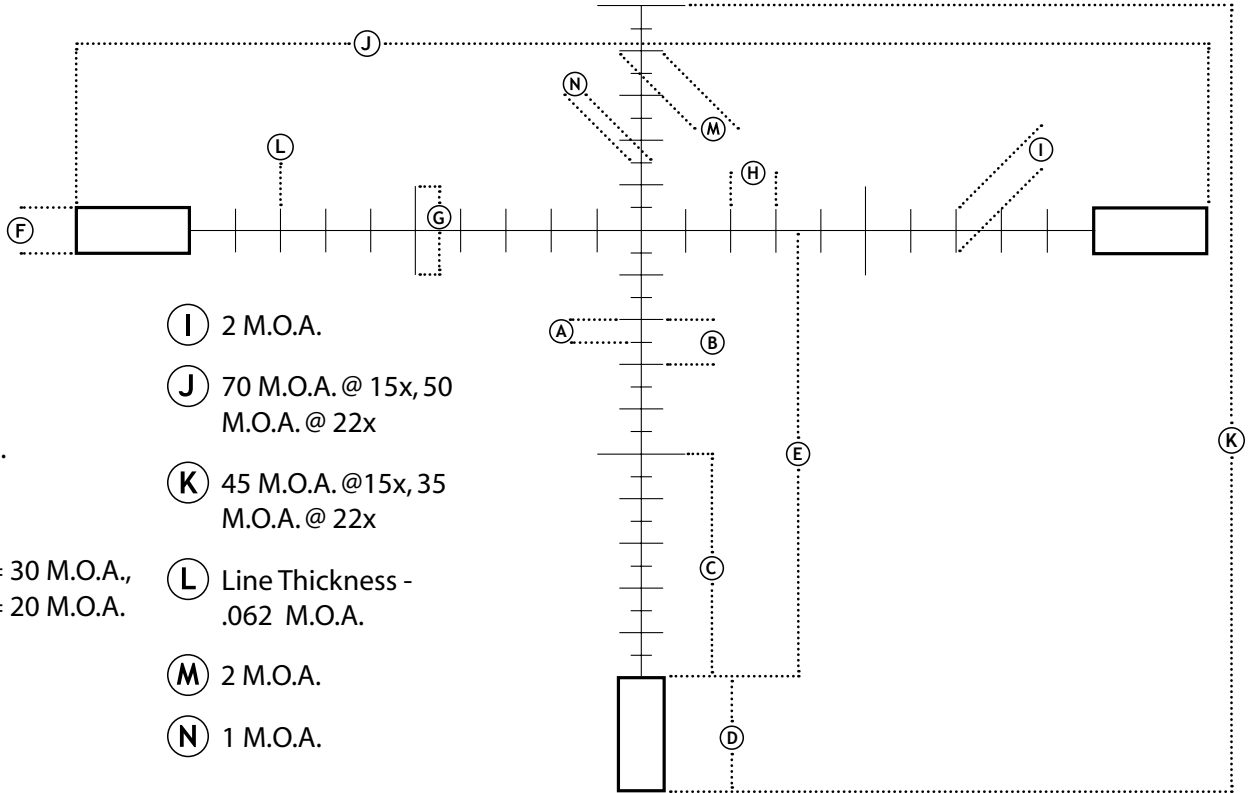

(A) 1 M.O.A.

(B) 2 M.O.A.

(C) 10 M.O.A.

(D) 5 M.O.A.

(E) 3.5-15x = 30 M.O.A.,
5.5-22x = 20 M.O.A.

(F) 2 M.O.A.

(G) 4 M.O.A.

(H) 2 M.O.A.

(I) 2 M.O.A.

(J) 70 M.O.A. @ 15x, 50
M.O.A. @ 22x

(K) 45 M.O.A. @ 15x, 35
M.O.A. @ 22x

(L) Line Thickness -
.062 M.O.A.

(M) 2 M.O.A.

(N) 1 M.O.A.

NP-R2

The Nightforce NP-R2 is a performance-proven reticle designed specifically to enhance a shooter's long range accuracy and ranging capabilities under a variety of field conditions. The NP-R2 allows the shooter to accurately range a target, utilize multiple zero points and select from numerous hold points to compensate for both windage and bullet drop.

Due to Nightforce's illumination technology, the glass etched reticle glows red and can be illuminated at different intensities. This technology ensures excellent reticle contrast in low light when illuminated or a well-defined black reticle when not illuminated. In addition, the fine line subtension (area of target covered) makes this reticle ideal for long range applications. Using the latest advancements in laser etching the shooter is guaranteed consistent spacings and therefore accurate range estimation. What makes the Nightforce NP-R2 reticle truly unique. The vertical line of the NP-R2 reticle is divided into 2 M.O.A. increments (approx. 2 inches at 100 yards). These vertical increments are used for range estimation, multiple zero points and accurate bullet drop compensation.

Any size target can be easily ranged using a simple formula: (target size in inches \div M.O.A. \times 100 = range in yards). Once range is determined select an appropriate hold point based on the bullet drop of your cartridge. The vertical spacings can easily be split into 1 M.O.A. increments further enhancing

long range accuracy. The horizontal line is divided into equal 5 M.O.A. increments for windage compensation.

Note: The 2.5-10x and 3.5-15x models have additional lines on the vertical and horizontal axes with the NP-R2 reticle. See Figure 2.

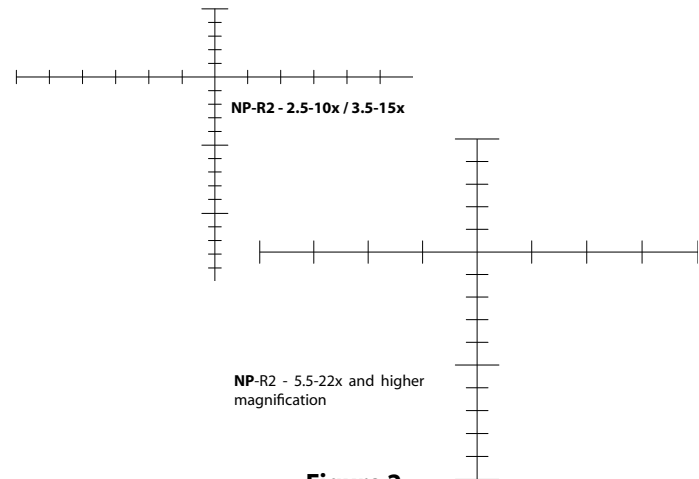
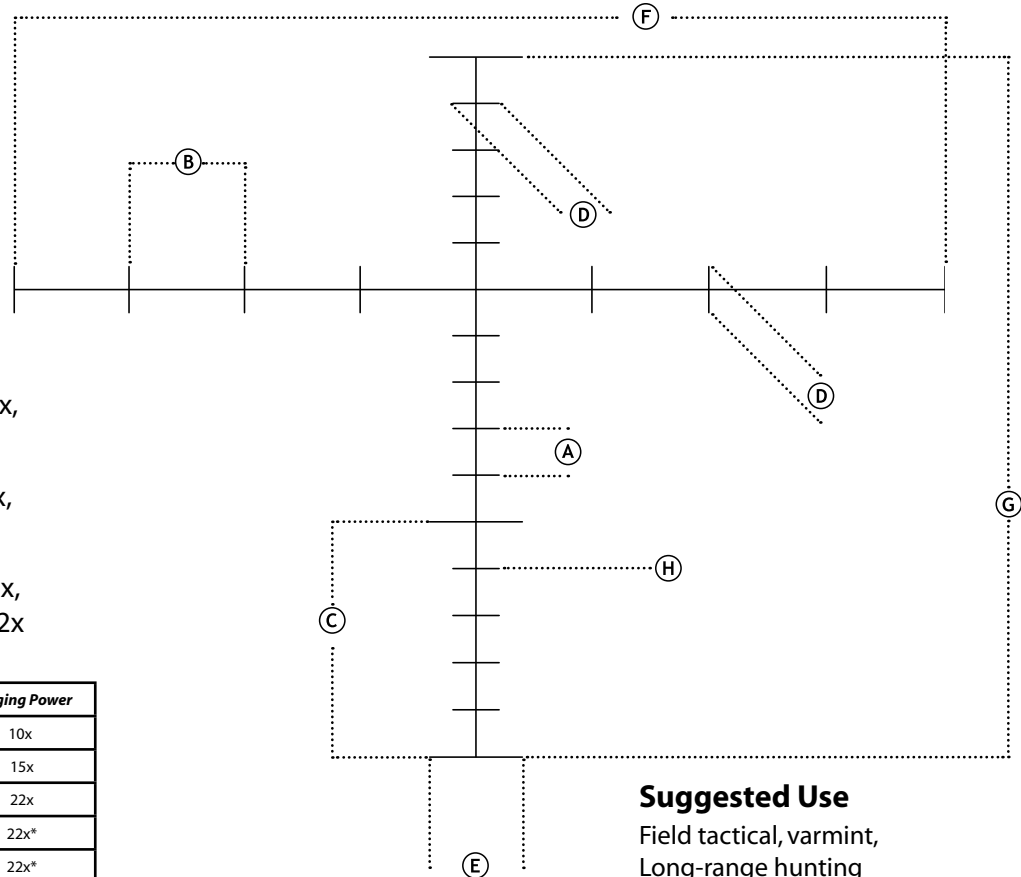

Figure 2

NP-R2

- (A) 2 M.O.A.
- (B) 5 M.O.A.
- (C) 10 M.O.A.
- (D) 2 M.O.A.
- (E) 4 M.O.A.
- (F) 60 M.O.A. @ 10x, 60 M.O.A. @ 15x,
40 M.O.A. @ 22x
- (G) 40 M.O.A. @ 10x, 40 M.O.A. @ 15x,
30 M.O.A. @ 22x
- (H) Line Thickness - .09 M.O.A. @ 10x,
.06 M.O.A. @ 15x, .06 M.O.A. @ 22x



Suggested Use
Field tactical, varmint,
Long-range hunting

<i>Riflescope Model</i>	<i>Ranging Power</i>
2.5-10x NXS	10x
3.5-15x NXS	15x
5.5-22x NXS	22x
8-32x NXS and Benchrest	22x*
12-42x NXS and Benchrest	22x*
*Signified by an "R" on the Power Zoom Ring	

NP-2DD

Favored by two classes of shooter, the NP-2DD is the reticle most preferred for predator hunting in low light conditions. When measured at 22x, tapered horizontal bars reaching 4 M.O.A. from the center and a floating .1875 M.O.A. center dot draw the hunter's eye to center for quick target acquisition with minimal illumination flare around the center aimpoint. This reticle is also highly functional for benchrest shooters when combined with Nightforce Precision Benchrest models. A secondary .125 M.O.A. diameter dot is located 8 M.O.A. below center at 22x. This dot is a 500-600 yard holdover point for most flat shooting cartridges. This simple and effective reticle performs in long range situations while maintaining quick target acquisition capability for short distances.

1,000 yard benchrest competitors prefer the NP-2DD reticle when selecting the 8-32x56 and 12-42x56 models in the Precision Benchrest series for its optimum dot subtension. The unobstructed field-of-view allows the shooter to observe the wind flags to detect a change of condition.

- Ⓐ 3.1 M.O.A. @ 15x, 2 M.O.A. @ 22x, 1.4 M.O.A. @ 32x, 1.1 M.O.A. @ 42x
- Ⓑ .30 M.O.A. @ 15x, .1875 M.O.A. @ 22x, .13 M.O.A. @ 32x, .10 M.O.A. @ 42x
- Ⓒ 12.6 M.O.A. @ 15x, 8 M.O.A. @ 22x, 5.7 M.O.A. @ 32x, 4.3 M.O.A. @ 42x
- Ⓓ 3.1 M.O.A. @ 15x, 2 M.O.A. @ 22x, 1.4 M.O.A. @ 32x, 1.1 M.O.A. @ 42x
- Ⓔ 6.3 M.O.A. @ 15x, 4 M.O.A. @ 22x, 2.9 M.O.A. @ 32x, 2.1 M.O.A. @ 42x
- Ⓕ 3.1 M.O.A. @ 15x, 2 M.O.A. @ 22x, 1.4 M.O.A. @ 32x, 1.1 M.O.A. @ 42x
- Ⓖ Dot Size = .20 M.O.A. @ 15x, .125 M.O.A. @ 22x, .09 M.O.A. @ 32x, .07 M.O.A. @ 42x

NP-2DD

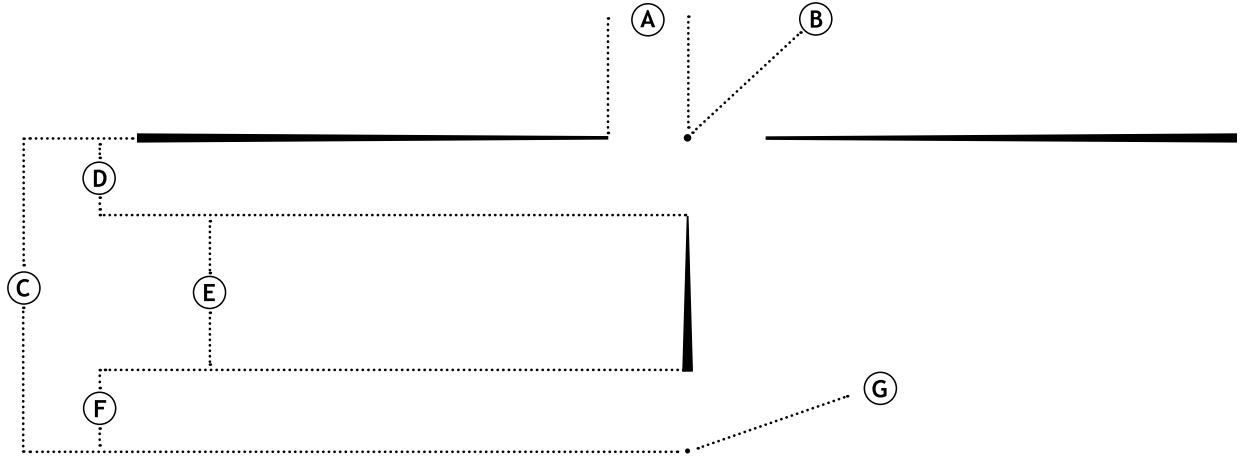

<i>Riflescope Model</i>	<i>Ranging Power</i>
3.5-15x NXS	15x
5.5-22x NXS	22x
8-32x NXS and Benchrest	22x*
12-42x NXS and Benchrest	22x*
*Signified by an "R" on the Power Zoom Ring	

Suggested Use

Varmint, 1000 yard benchrest

CH-1

Designed for benchrest competition, the CH-1 reticle is a popular choice for a broad range of benchrest shooters. A subtension of .036 M.O.A. measured at 22x was selected after extensive research by Nightforce to offer competitors a reticle with an optimum subtension best suited for benchrest competition.

The CH-1 provides an unobstructed field-of-view, allowing the shooter to observe the wind flags to detect a change of conditions.

Suggested Use

Benchrest

Ⓐ Line Thickness

0.019 M.O.A. @ 42x

0.025 M.O.A. @ 32x

0.036 M.O.A. @ 22x

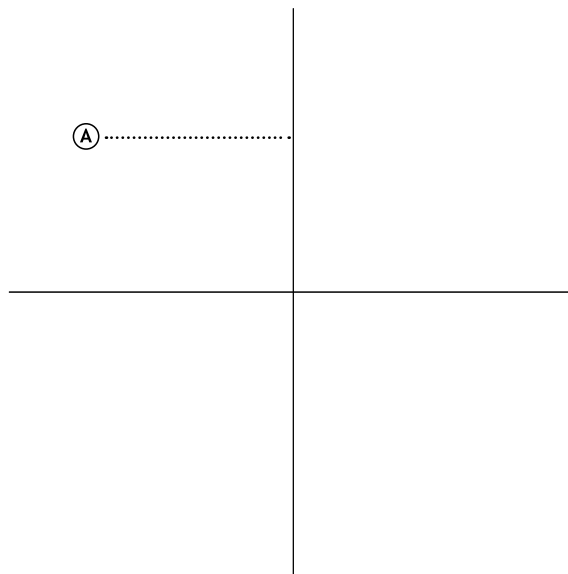

<i>Riflescope Model</i>	<i>Ranging Power</i>
5.5-22x NXS	22x
8-32x NXS and Benchrest	22x*
12-42x NXS and Benchrest	22x*
*Signified by an "R" on the Power Zoom Ring	

CH-2

Designed for long range, high power competition, the CH-2 features a .200 M.O.A. dot on a .036 M.O.A. crosshair when measured at 22x. This .200 M.O.A. dot is calibrated for scored shooting on standard NRA high power competition targets.

This reticle was designed in response to extensive research conducted by Nightforce with the cooperation of the world's foremost high power competitors. Nightforce is proud the United States Army Marksmanship Unit has chosen the CH-2 over all reticles for high power competition.

USAMU's use of this reticle in 5.5-22x56 NXS demonstrates Nightforce's achievement in developing the best scope and reticle combination for the elite sport of long range, high power competition.

Suggested Use

High-power competition

- A** Line Thickness
0.019 M.O.A. @ 42x
0.025 M.O.A. @ 32x
0.036 M.O.A. @ 22x

- B** Dot Diameter
0.110 M.O.A. @ 42x
0.140 M.O.A. @ 32x
0.200 M.O.A. @ 22x

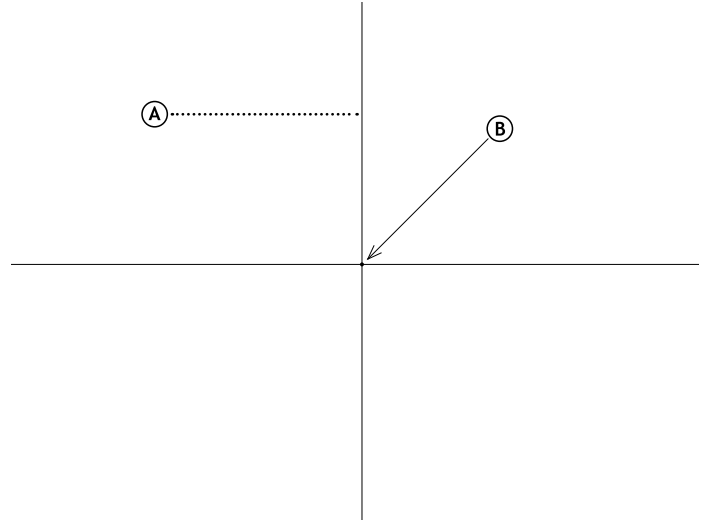

<i>Riflescope Model</i>	<i>Ranging Power</i>
5.5-22x NXS	22x
8-32x NXS and Benchrest	22x*
12-42x NXS and Benchrest	22x*
*Signified by an "R" on the Power Zoom Ring	

CH-3

Designed for benchrest shooting, the CH-3 reticle features an extremely fine crosshair and dot.

This fine crosshair and floating dot creates the perfect long range benchrest reticle to compensate for mirage and wind conditions in 1 M.O.A. increments. Combined with a high magnification and variable power, the CH-3 allows the competition shooter to bracket the bullseye while maintaining a center aim point.

Note: Only the dot is illuminated on the CH-3 reticle.

Suggested Use

Benchrest

- (A)** Line Thickness
.016 M.O.A. @ 42x
.022 M.O.A. @ 32x
.030 M.O.A. @ 22x
- (B)** Dot Diameter
.07 M.O.A. @ 42x
.09 M.O.A. @ 32x
.125 M.O.A. @ 22x
- (C)** Distance between center of line or dot and end of line
.54 M.O.A. @ 42x
.72 M.O.A. @ 32x
1.0 M.O.A. @ 22x

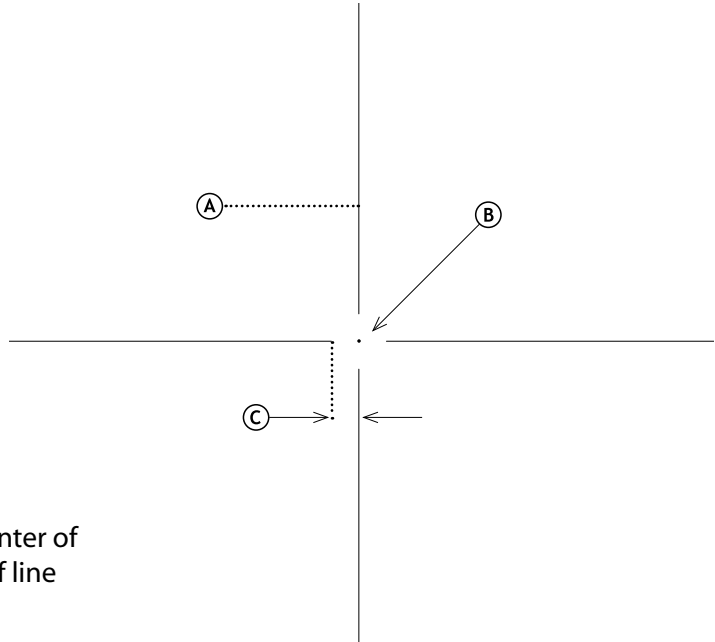

Riflescope Model	Ranging Power
5.5-22x NXS	22x
8-32x NXS and Benchrest	22x*
12-42x NXS and Benchrest	22x*
*Signified by an "R" on the Power Zoom Ring	

MLR

The MLR reticle is ideally suited for field tactical and long range applications.

The 1 mil and 1/2 mil divisions allow for multiple zeroes, hold-over, hold-under and windage adjustments without touching the elevation or windage knobs.

Additionally, there are 1/4 mil marks at the 12:00 and 3:00 positions to aid in more precise range estimation.

This reticle along with the Mil-Dot works well with the optional Milradian Turrets.

Suggested Use

Field tactical, long-range hunting

- Ⓐ 2.5 Milradian @ 15x (3.5-15x NXS only)
- Ⓑ 5 Milradian @ 15x, 2 Milradian @ 22x
- Ⓒ .25 Milradian
- Ⓓ .50 Milradian
- Ⓔ 1 Milradian
- Ⓕ .50 MILRADIANT
- Ⓖ Line Size @ 15x and 22x = 1/16 Mil Long with a 1/16 Mil gap spacing between them and the main reticle line, for a total space of 1/8 Mil.
- Ⓗ Line thickness .013 @ 15x, .093 Milradian at 22x

MLR

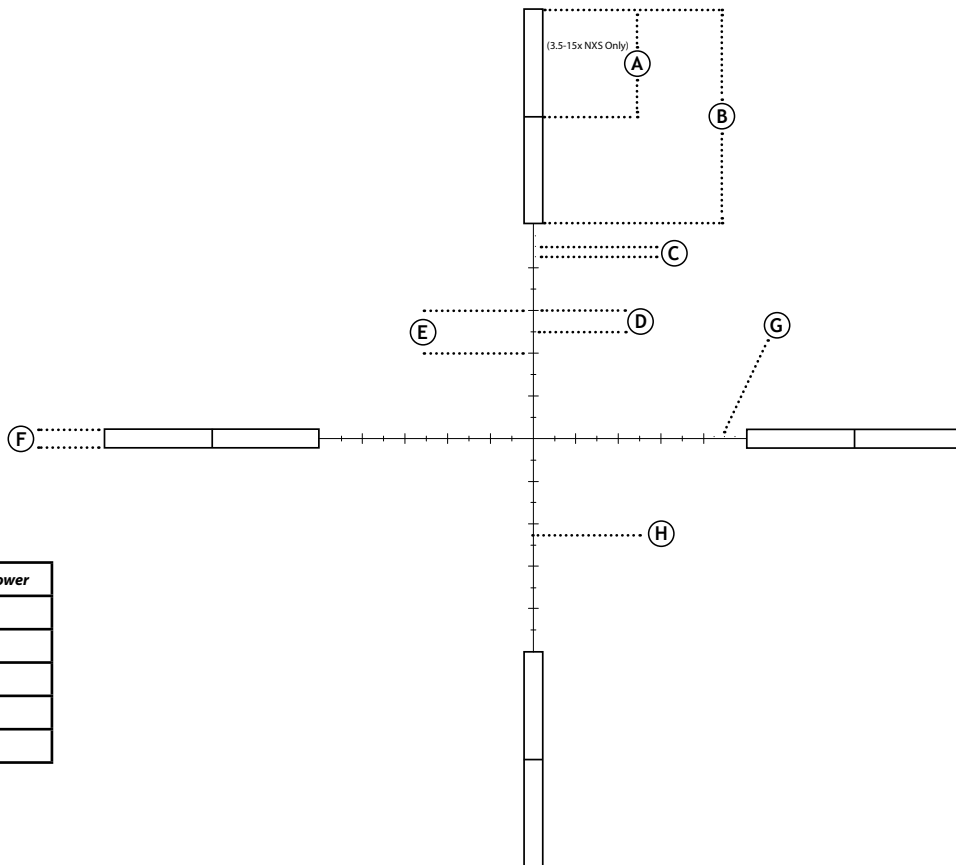

<i>Riflescope Model</i>	<i>Ranging Power</i>
3.5-15x NXS	15x
5.5-22x NXS	22x
8-32x NXS	22x*
12-42x NXS	22x*
*Signified by an "R" on the Power Zoom Ring	

MIL-DOT

Developed by the military, the mil-dot reticle allows the sniper to estimate the range to his target. The mil-dot is now the standard reticle found in law enforcement rifle scopes.

Advanced developments at Nightforce have resulted in the creation of a new style of mil-dot reticle. Rather than the solid dots that obscure most of the target, the Nightforce mil-dot reticle consists of see-through round dots which are placed on the vertical and horizontal cross lines that serve as reference points. In addition, all four posts are also see-through. Because both the dots and posts are clear, the target is no longer obscured. As a result, these features enable the sniper to more accurately estimate the range to his target.

The dots are spaced precisely 1 mil apart which represents 3.6 inches at 100 yards at specified power. The mil-dot design is etched on precision multi-coated compound glass. This eliminates breakage and misalignment of the reticle. Because of Nightforce's illumination technology, the glass etched reticle glows red and can be illuminated at different intensities. This flexibility ensures excellent reticle contrast in low light when illuminated or a well-defined black reticle when not illuminated.

- Ⓐ 7 Milradian @ 4x, 5 Milradian @ 10x, 5 Milradian @ 15x, 2 Milradian @ 22x
- Ⓑ 1 Mil (3.43775 M.O.A. / 3.6" @ 100 yards)
- Ⓒ .5 Milradian @ 4x, .45 Milradian @ 10x, .45 Milradian @ 15x, .46 Milradian @ 22x
- Ⓓ Line Thickness = .1875 M.O.A. @ 4x, .13 M.O.A. @ 10x, .13 M.O.A. @ 15x, .093 M.O.A. @ 22x
- Ⓔ Line Thickness = .30 M.O.A. @ 4x, .20 M.O.A. @ 10x, .20 M.O.A. @ 15x, .21 M.O.A. @ 22x
- Ⓕ 1/16 Milradian
- Ⓖ 1/4 Mil
- Ⓗ 1/8 Mil
- Ⓘ 1/32 Mil (No center dot on 1-4x NXS)

MIL-DOT

Suggested Use

Field tactical

<i>Riflescope Model</i>	<i>Ranging Power</i>
1-4x NXS	4x
2.5-10x NXS	10x
3.5-15x NXS	15x
5.5-22x NXS	22x
8-32x NXS and Benchrest	22x*
12-42x NXS and Benchrest	22x*
*Signified by an "R" on the Power Zoom Ring	

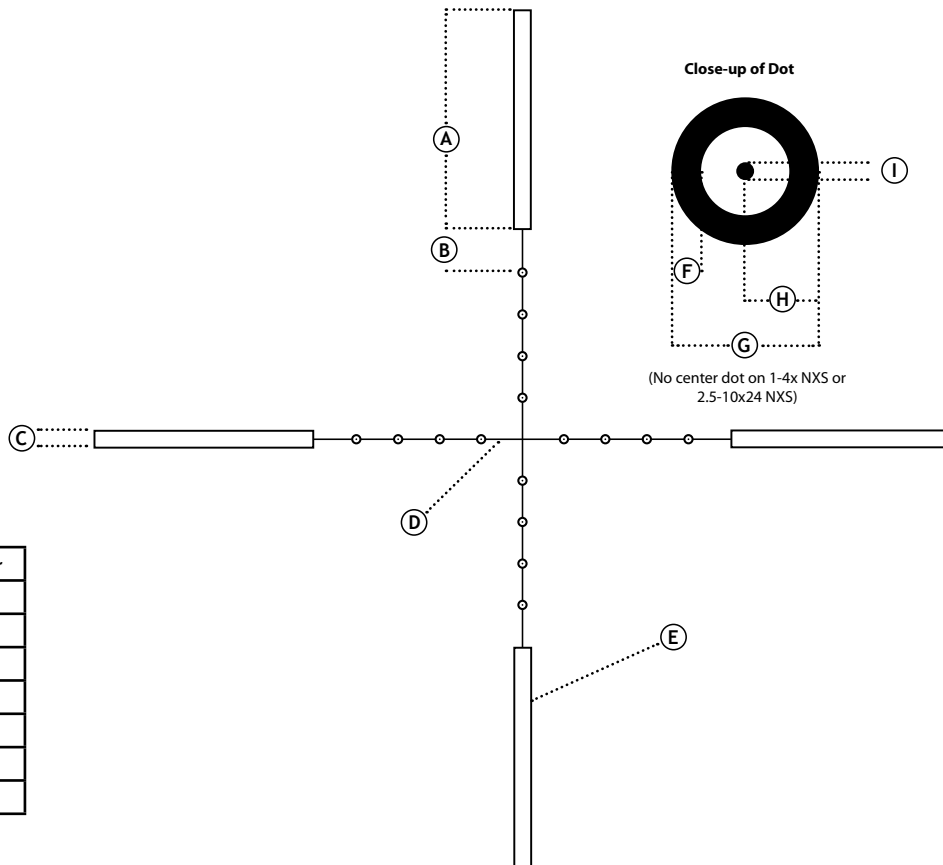

FC-2

Created for close to medium range use in military, law enforcement or hunting applications, the FC-2 provides a highly visible naturally centering aiming point. The center dot gives a finer aiming point and the larger circle a wider zone for fast or moving shots.

The triangular aiming point under the circle can be used as a 10 M.O.A. holdover point from the center dot, and as a ranging tool in combination with the circle and dot.

- (A) 10 M.O.A.
- (B) 2 M.O.A. for 1-4x, 1.5 M.O.A. - for 2.5-10x
- (C) 5 M.O.A.
- (D) 5 M.O.A.
- (E) 15 M.O.A.
- (F) 40 M.O.A. for 1-4x, 30 M.O.A. for 2.5-10x
- (G) Line Thickness = .50 M.O.A. @ 4x, .30 M.O.A. @ 10x

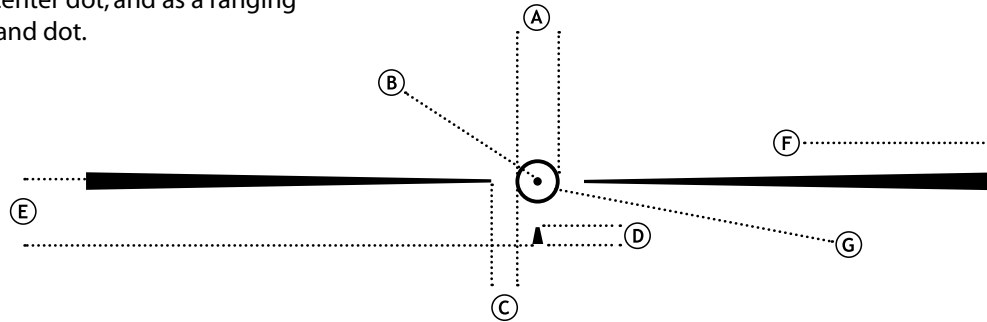

Riflescope Model	Ranging Power
1-4x NXS	4x
2.5-10x NXS	10x

The tapered horizontal lines on either side lead the eye to the center of the reticle and provide good contrast against the target in low light situations and with cluttered backgrounds. This reticle is the number one choice on the 1-4x NXS.

Note: for the 1 -4x NXS only the center dot and surrounding circle illuminate with the FC-2 reticle.

For the 2 -10x NXS the whole reticle illuminate.

Suggested Use

CQB, hunting

Ranging

Any reticle that has at least two reference points of a known distance in M.O.A. or Mils can be used for range estimation to some extent. One of the easiest reticles to understand is the NP-R1 with its 1 M.O.A. spacing between the vertical stadia tic marks. If you know the size of your target then you can use the M.O.A. spacing between points on the reticle to estimate the distance to your target. You can create a reference chart that lists the type of targets or game you will be engaging and their M.O.A. size at the various ranges you may encounter them.

Example – 20" high target using the NP-R1 reticle with the power zoom ring **set at the ranging mark**.

At 100 yards this spacing will fit between 20 lines on the vertical stadia.

200 yards - 10 lines

300 yards - 6.5 lines

400 yards - 5 lines

500 yards - 4 lines

600 yards – 3.3 lines

700 yards – 2.9 lines

800 yards – 2.5 lines

900 yards – 2.2 lines

1000 yards - 2 lines

You may change the power zoom ring setting to increase the M.O.A. spacing between marks on the reticle. Halving the power doubles the distance. For example with the 5.5-22x the spacing is 1 M.O.A. between the horizontal lines, at 11x the spacing becomes 2 M.O.A., which will allow you to range larger or closer targets more easily.

Even a very simple reticle design such as the NP-1, can still be used for limited ranging of some targets. The distance between the center of the reticle and the beginning of the thicker line at the 6:00 position is 2 M.O.A at 22x. This could be used to range a target that was 20" high at 1000 yards. By changing the power zoom to 5.5x the spacing becomes 8 M.O.A., which could be used to range a 16" target at 200 yards, a 48" target at 600 yards or an 80" target at 1000 yards.

You can customize your reticle subtension at desired power zoom settings for your Nightforce scope by utilizing the custom feature on our Nightforce ballistic software.

For a more detailed explanation of using various points on the reticle to estimate range to the target refer to the NP-1RR reticle on page 2.

Please visit www.nightforceoptics.com for additional information on using your reticle.

Notes



NIGHTFORCE™

©Nightforce Optics, Inc. 2008

North America and military sales:

Nightforce Optics, Inc.
1040 Hazen Lane
Orofino, ID 83544
tel 208.476.9814
fax 208.476.9817
NightforceOptics.com

International sales:

Lightforce Australia PTY LTD.
28 Orsmond Street
Hindmarsh, SA 5007
Australia
tel 08.8340.2766
(International +618.8340.2766)
fax 08.8346.0504
(International +618.8346.0504)
Lightforce.com

**Precision optics for
precision shooting**